

CFM2100R CRIMP FORCE MONITOR

For automatic wire processing machines

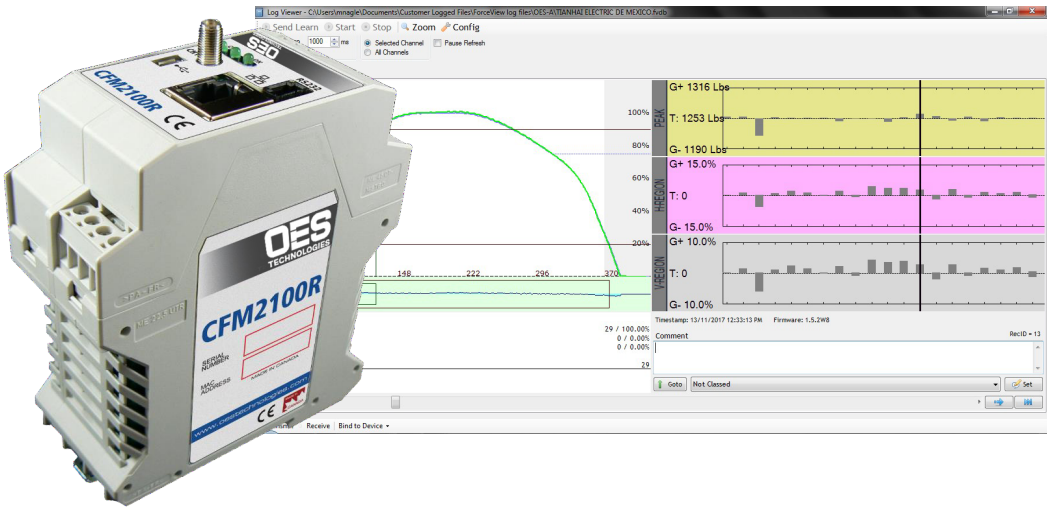

One Channel

Reliability

- Crimp defects are effectively detected and differentiated from normal crimp process variation.
- In-process monitoring and detection of crimp defects including insulation inside conductor crimp, missing strands, change in crimp dimension, deformed crimp, twisted terminal, worn or broken tooling, change in crimp material, variation in the crimp bell mouth.

Flexibility

- Adaptable to a wide range of automatic wire processing machines.
- Configurable features and options for integration with the wire processing machine functions.
- Data management features for data logging, exporting, part number entry and management.
- Language configurable.

Traceability

- 100% production traceability when connected to ForceView.
- Stores data for playback or export into production and quality reports.

Performance

- Advanced crimp force algorithms deliver the highest level of crimp defect detection with minimum false rejects.
- Consistent and reliable crimp defect detection for a wide range of terminal and wire crimping combinations.
- Common configuration settings support efficient and error-free machine setup.
- ForceView displays graphic detail of the crimping process, reveals process variation associated with crimping defects, and variations in the process.

Patents

1998 us Patent No. 5,841,675
2008 US Patent No. 7,333,906 B2
2014 US Patent Pending

Quick Facts

Model	Application
CFM2100R 1 Channel	Bench Press Automatic Machine
Sensor Options	
Piezo Strain Piezo Force Ring PBT Force Sensor	✓ ✓ ✓
Technical Specifications	
Operating Environment	15 to 50C 60 to 120F
Supply Voltage	24VDC
Communications	1 Ethernet RJ45 1 USB 2.0 1 RS232
Digital Inputs 1 Channel	2
Digital Outputs 1 Channel	3
Mounting	DIN Rail
Dimensions	135.45 x 45.2 x 99.0mm

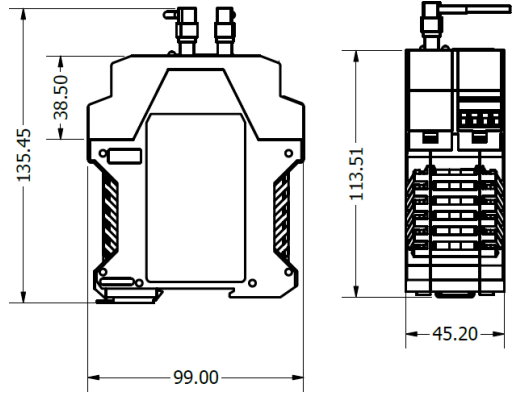

FORCEView™

ForceView is a powerful graphical user interface software for monitoring the crimping process relative to the crimp process tolerance limit.

Data from each crimp is captured for 100% traceability. Configuration parameters are automatically loaded using the part number selection feature. ForceView integrates seamlessly with the machine production management software.

About OES Technologies

OES Technologies products and technologies are developed specifically for the wire processing industry to monitor and inspect 100% of parts produced during the manufacturing process and prevent part defects from entering the supply chain. OES's dedication to innovation enables them to deliver a steady stream of cutting edge technologies that meet the exacting demands of this ever changing market.

www.oestechnologies.com

technologies@oes-inc.com



OES Technologies

**4056 Blakie Road
London Ontario,
Canada
N6L 1P7**